

FCI CONFIDENTIAL

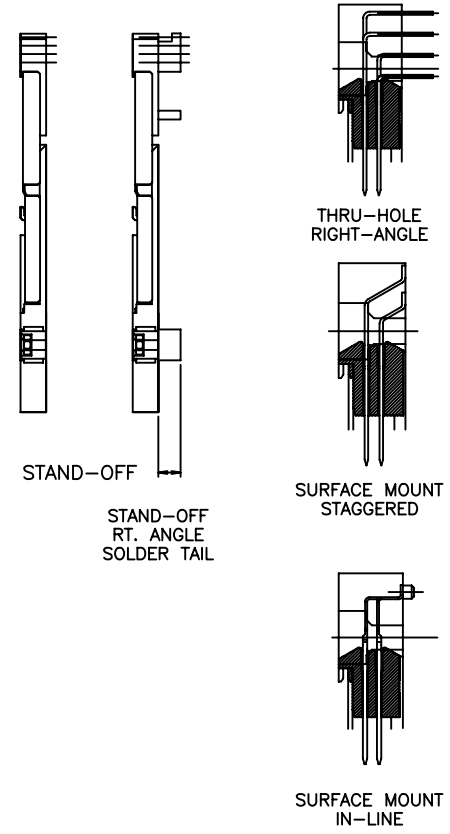

This document is the property of and embodies CONFIDENTIAL and PROPRIETARY information of FCI. No part of the information shown on this document may be used in any way or disclosed to others without the written consent of FCI. Copyright FCI.

PCMCIA COMPONENTS:
SINGLE DECK ASSEMBLY

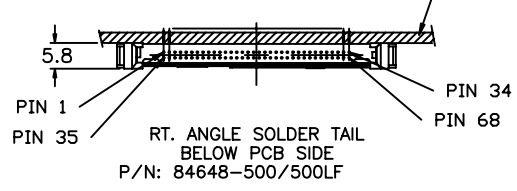
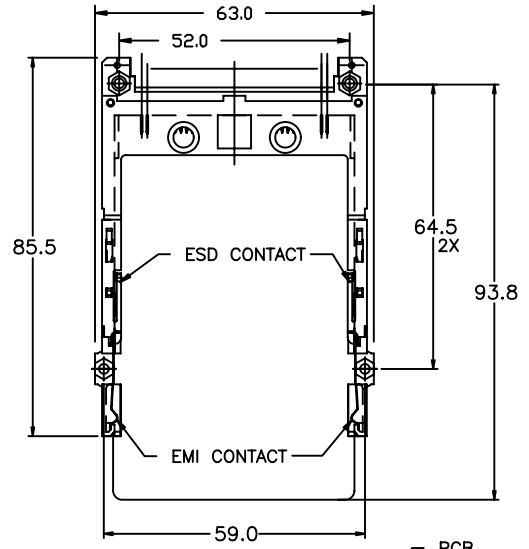
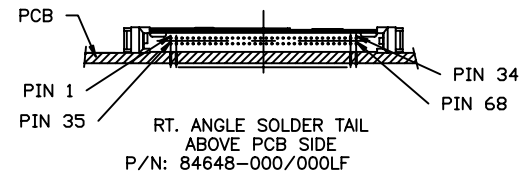
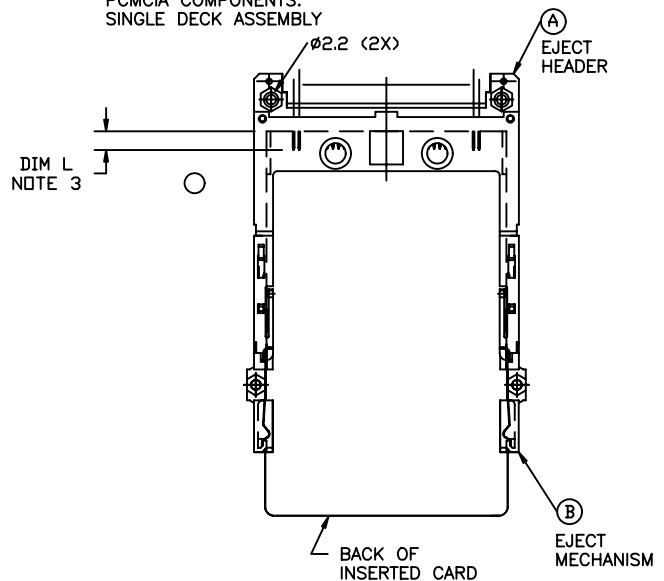

- NOTES:
- REFER TO HEADER DRAWING 94898 AND NON-EJECT MECHANISM 92791 FOR ADDITIONAL DIMENSIONS, MATERIAL, AND PLATING INFORMATION.
 - REFER TO TA-946 FOR PCB LAYOUT AND PCB KEEP-OUT AREA.
 - RECOMMENDED SCREW TORQUE: 1.0 TO 1.5 MAX in-lbs. (1.2-1.7 cm-kgs).
 - PCB SIDE IS AS APPEARS INSTALLED.
 - SOLDER TAIL KEY:
R/A = RIGHT ANGLE PIN-THROUGH-HOLE
SMT-STG = STAGGERED SURFACE MOUNT
SMT-IL = SURFACE MOUNT IN-LINE (SINGLE ROW)

4.25±0.1	3.5±0.1	5.0±0.1
OTHERS	36,67	1,17,34,35,51,68

- ADD "H" TO PART NUMBER FOR OPTIONAL HOLD DOWN (4 PER ASSEMBLY)

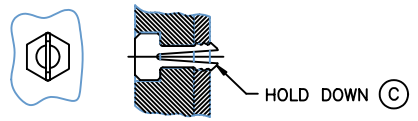

- ADD "LF" TO PART NUMBER FOR LEAD-FREE TYPE.
- IF LEAD FREE P/N. THE HOUSING WILL WITHSTAND EXPOSURE TO 260°C PEAK TEMPERATURE
SOLDER TAIL : SMT-IL, SMT-STG CAN RESIST 40 SECONDS IN A CONVECTION, INFRA-RED OR VAPOR PHASE REFLOW OVEN.
SOLDER TAIL : R/A CAN RESIST 10 SECONDS IN A WAVE SOLDER APPLICATION WITH A 1.00MM MINIMUM THICK CIRCUIT BOARD.
- IF LEAD FREE P/N. THE PRODUCT MEETS EUROPEAN UNION DIRECTIVES AND OTHER COUNTRY REGULATIONS AS DISCRIBED IN GS-22-008
- LEAD FREE P/N PACKAGING MEETS GS-14-920 SPECIFICATION

mat'l. code		surface		tolerance		projection		product family	
		ISO 1302		ISO 406 ISO 1101				PCMCIA	
ltr		ecn no		dr		date		title	
L		N05-0052		WB		02/24/05		68 POS. 3.3VNON-EJECT HEADER ASSEMBLY	
M		N05-0181		WB		06/21/05			
N		N05-0190		WB		07/01/05			
P		N06-0065		MZ		03/14/06		dr	
R		N07-0245		MZ		10/09/07		enr	
S		N08-0099		MZ		05/19/08		chr	
								appd	
								D.BRANN	
								6/22/98	
								6/22/98	
								6/22/98	
sheet		revision		S		S		S	
index		sheet		1		2		3	



PCMCIA COMPONENTS: SINGLE DECK ASSEMBLY

PCB SIDE ④	SOLDER TAIL ⑤	STANDOFF (MM)	Ⓐ EJECT HEADER	Ⓑ EJECT MECHANISM	Ⓒ NOTE ⑥ HOLD DOWN	QTY.	TO MAKE FINAL ASSY PART NUMBER	MOUNTING STYLE TO P.C.B.
ABOVE	R/A	NONE	94898-000	92791-001			84648-000	
ABOVE	R/A	NONE	94898-000	92791-001	93925-001	4	84648-000H	
ABOVE	R/A	2	94898-040	92791-021			84648-020	
ABOVE	R/A	2	94898-040	92791-021	93925-002	4	84648-020H	
ABOVE	R/A	4	94898-010	92791-041			84648-040	
ABOVE	R/A	4	94898-010LF	92791-041			-040LF	
ABOVE	R/A	4	94898-010	92791-041	93925-003	4	84648-040H	
ABOVE	R/A	4	94898-010LF	92791-041	-003	4	-040HLF	
ABOVE	R/A	5	94898-020	92791-051			84648-050	
ABOVE	R/A	5	94898-020	92791-051	93925-004	4	84648-050H	
ABOVE	R/A	5	94898-020MLF	92791-051M	93925-011	4	84648-050HLF	
ABOVE	R/A	5	94898-020	92791-051	63284-104	2	84648-055	
ABOVE	R/A	5	94898-020MLF	92791-051M	63284-104	2	84648-055LF	
ABOVE	R/A	5	94898-021MLF	92791-051M	63284-011	4	84648-051HLF	
ABOVE	SMT-IL	NONE	94898-002	92791-001			84648-002	
ABOVE	SMT-IL	NONE	94898-002LF	92791-001			-002LF	
ABOVE	R/A	NONE	94898-000LF	92791-001			84648-000LF	
ABOVE	R/A	NONE	94898-000LF	92791-001	93925-001	4	84648000HLF	
ABOVE	R/A	2	94898-040LF	92791-021			84648-020LF	
ABOVE	R/A	2	94898-040LF	92791-021	93925-002	4	84648020HLF	
ABOVE	R/A	5	94898-020LF	92791-051			84648-050LF	
ABOVE	SMT-IL	NONE	94898-002	92791-001	93925-001	4	84648-002H	
ABOVE	SMT-STG	NONE	94898-001	92791-001			84648-001	
ABOVE	SMT-IL	NONE	94898-002LF	92791-001	-001	4	84648002HLF	
ABOVE	SMT-STG	NONE	94898-001LF	92791-001			84648001LF	
BELOW	R/A	NONE	94898-500	92791-001			84648-500	
BELOW	R/A	2	94898-540	92791-021			84648-520	
BELOW	R/A	4	94898-510	92791-041			84648-540	
BELOW	R/A	5	94898-520	92791-051			84648-550	
BELOW	R/A	5	94898-520	92791-051	93925-004	4	84648-550H	
BELOW	R/A	NONE	94898-500LF	92791-001			84648-500LF	
BELOW	R/A	2	94898-540LF	92791-021			84648-520LF	
BELOW	R/A	4	94898-510LF	92791-041			84648-540LF	
BELOW	R/A	5	94898-520LF	92791-051			84648-550LF	
BELOW	R/A	5	94898-520LF	92791-051	93925-004	4	84648550HLF	
BELOW	SMT-IL	NONE	94898-502	92791-001			84648-502	
BELOW	SMT-IL	NONE	94898-502	92791-001	93925-001	4	84648-502H	
BELOW	SMT-STG	NONE	94898-501	92791-001			84648-501	
BELOW	SMT-IL	NONE	94898-502LF	92791-001			84648-502LF	
BELOW	SMT-IL	NONE	94898-502LF	92791-001	93925-001	4	84648502HLF	
BELOW	SMT-STG	NONE	94898-501LF	92791-001			84648-501LF	

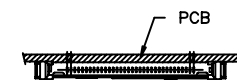
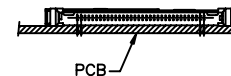

mat'l. code		surface	tolerance	projection	product family
		ISO 1302	ISO 406 ISO 1101		PCMCIA
ltr	ecn no	dr	date	title	
S				68 POS. 3.3VNON-EJECT HEADER ASSEMBLY	
		angles	linear	title	
		.X±.3	.XX±.13	84648	
		±2'	.XXX±.051	sheet 2of 3 size	
		dr	R.GRAPE	A4	
		engr	D.BRANN	84648	
		chr	D.BRANN	type CUSTOMER Drawing	
		appd	D.BRANN	6/22/98	
sheet	revision				
index	sheet				

FCI CONFIDENTIAL



FCIconnect.com

This document is the property of and embodies CONFIDENTIAL and PROPRIETARY information of FCI. No part of the information shown on this document may be used in any way or disclosed to others without the written consent of FCI. Copyright FCI.

FCI CONFIDENTIAL

FCI

FCIconnect.com

This document is the property of and embodies CONFIDENTIAL and PROPRIETARY information of FCI. No part of the information shown on this document may be used in any way or disclosed to others without the written consent of FCI. Copyright FCI.

PRODUCT NO.
84648-055/055LF

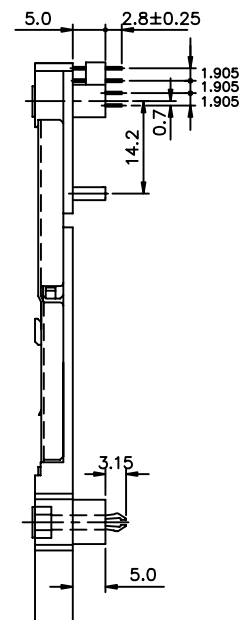
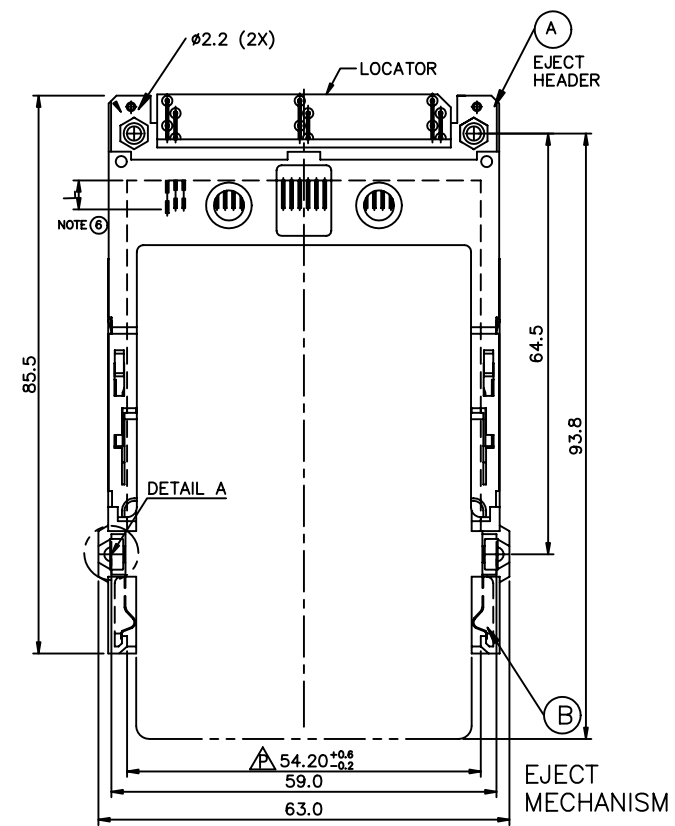

- 84648-X X X X X
- OPTIONAL LEED FREE NONE : N 0
LF : YES
 - OPTIONAL HOLD DOWN NONE : N 0
H : YES (SEE FIGURE OF -xxxH)
 - SOLDER TAIL 0 : R/A
1 : SMT STAGGERED
2 : SMT IN LINE
5 : R/A
 - STAND OFF 0 : 0mm
2 : 2mm
4 : 4mm
5 : 5mm
 - MOUNTING STYLE 0 : TOP MOUNTING
5 : BOTTOM MOUNTING

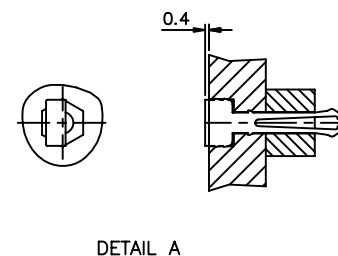
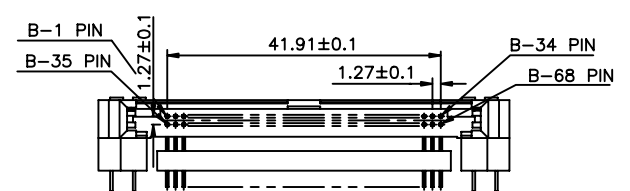

mat'l. code		surface	tolerance	projection	product family
		ISO 1302	ISO 406 ISO 1101		PCMCIA
ltr	ecn no	dr	date	tolerances unless otherwise specified	
S				angles	linear
				.X±.3	.XX±.13
				±2'	.XXX±.051
				dr	R.GRAPE 6/22/98
				enr	D.BRANN 6/22/98
				chr	D.BRANN 6/22/98
				appd	D.BRANN 6/22/98
sheet	revision				
index	sheet				

title		product family	
68 POS. 3.3VNON-EJECT HEADER ASSEMBLY		PCMCIA	
dwg no	sheet	3 of 3	size
84648			A4
type		CUSTOMER Drawing	